

»FUTURA-mini« series

The filling unit protects devices connected downstream by ensuring a gradual build-up of pressure. The unit consists of a 3/2-way valve including silencer and a filling valve (start-up valve). It is connected and disconnected by means of the 3/2-way valve. The filling time can be altered by turning the adjusting screw.

Input pressure	2.5 - 12 bar
Temperature range	-10 °C to 50 °C
Medium	Compressed air, neutral gases
Housing	PA66 GF60
Connecting thread	Plastic
Flow rate	1400 l/min
Flow rate measurement	At P ₂ = 6 bar and pressure drop Δ _p = 1 bar

Filling unit, pneumatically operated, adjustable filling time

Art. No.	Type No.	Thread	Size
142529	FUM 919	G 1/4	0

Accessories / spare parts

Art. No.	Type No.	Description
143105	H 848	Mounting bracket, incl. 2 screws
143010	WKM 100	Coupling package for wall mounting incl. 2 screws and O-ring
143022	KPM 100	Coupling package incl. 2 screws and O-ring
100405	568-2	Silencer
152077	WK 100-14	Wall bracket with connection thread G 1/4

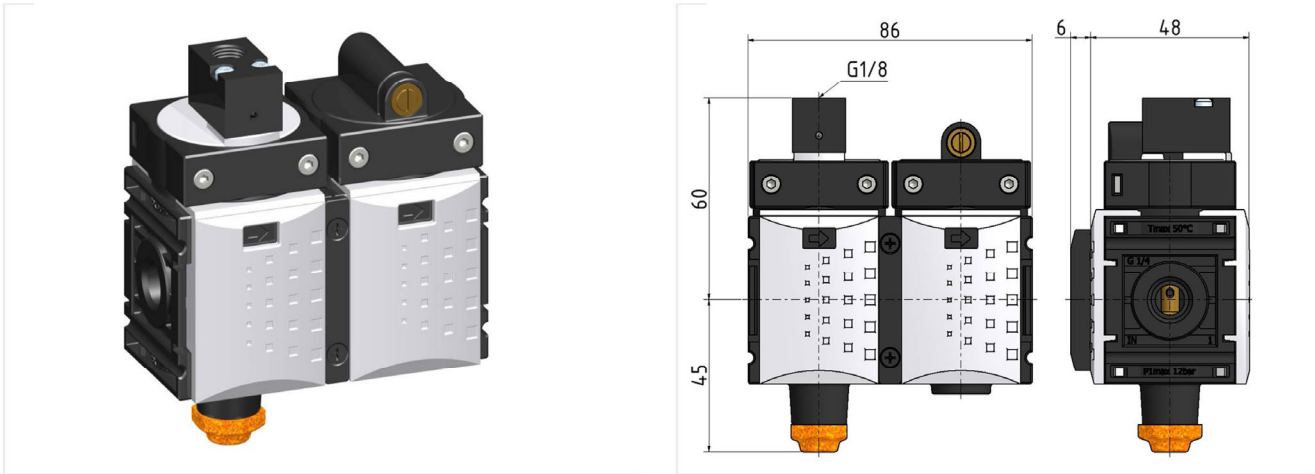

Durchflussdiagramm

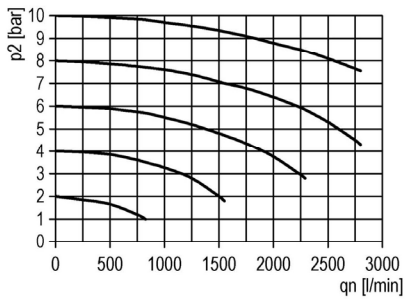

Symbole

